

Customer Journey Model

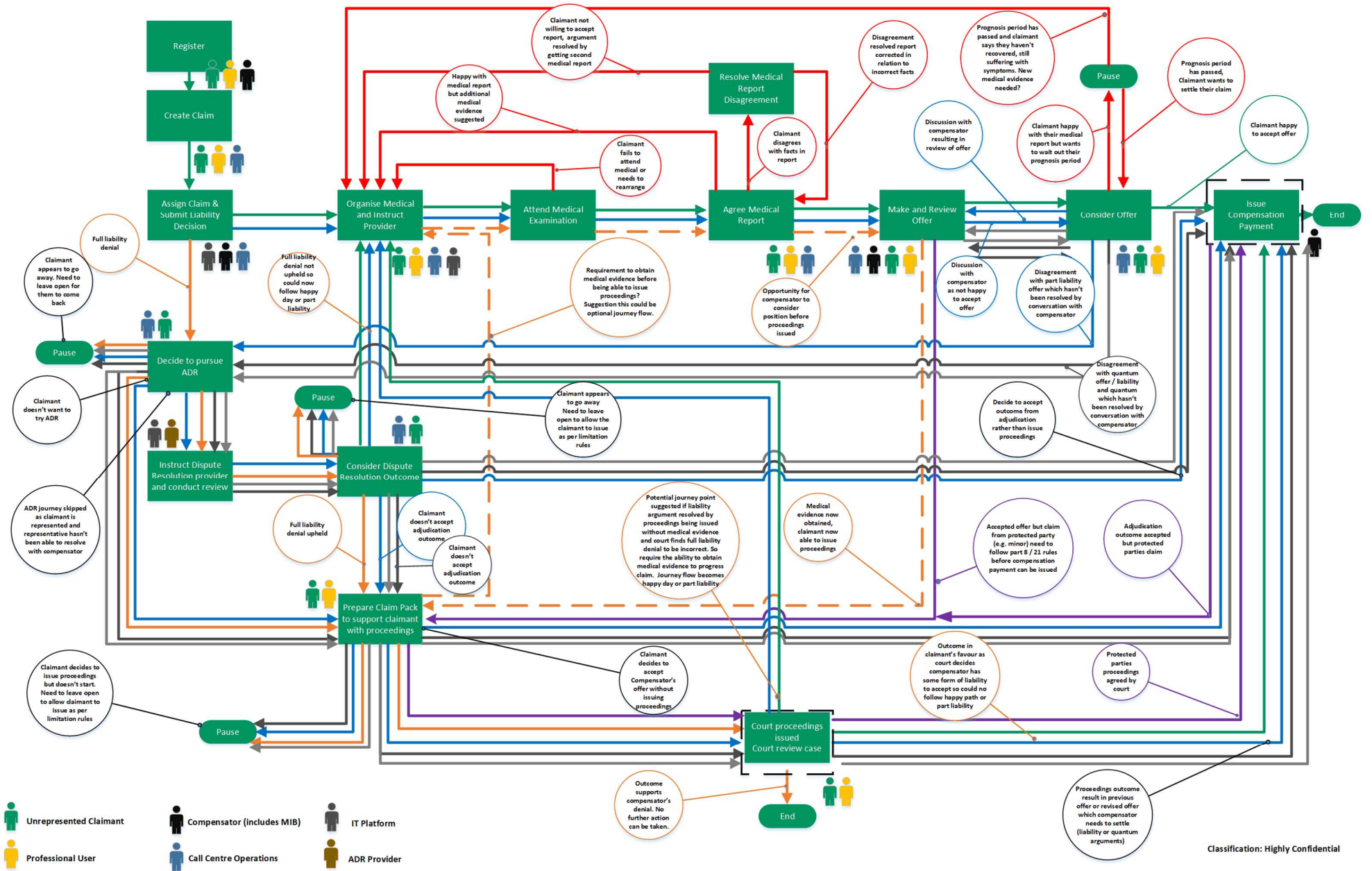

KEY

Journey Paths



Happy Day (100% Liability Accepted)



Part Liability and Quantum Dispute



Full Liability Denial



Medical Exception Paths
(Not all paths are handled within new
service e.g. Professional Users continue to
use MedCo as now)



Part Liability Offer



Quantum Dispute (only)



Full Liability Denial (optional path identified)



Claim involves Minor / Protected Parties



Activity Occurs Outside Service